

TALENTUM®

AIR PURGE ADAPTER

12556-00

To complement your Talentum installation, we also offer a comprehensive range of accessories and tools for your specialist application.

The Air Purge Adapter is intended to be mounted in between a Flame Detector and adjustable mounting bracket, with the Air Purge Adapter nozzle positioned to channel air from the inlet onto the window of the flame detector to prevent obscuration by particles.



INSTALLATION

The Air Purge Adapter should be connected to an external air supply via the female 1/4" BSP non return valve.

The air should be oil free and dry with a pressure range from 7 psi (0.5 Bar) to 50 psi (3.5 Bar).

If the air is not required continuously to keep the viewing window clean then a pulse of air can be supplied at regular intervals.

CAUTION: This product is not suitable for use in ATEX zone 0 – For use in ATEX zone 1/2I or 2/222, air must be clean and the system blown through before placing in a hazardous environment.

TALENTUM FLAME DETECTORS

1658I	Flame Detector IR2
1657I	Flame Detector IR2 (I.S)
165II	Flame Detector IR2 (Ex d)
1659I	Flame Detector UV/IR2
16589	Flame Detector IR3
16579	Flame Detector IR3 (I.S.)
16519	Flame Detector IR3 (Ex d)

ACCESSORIES

07127-00	Adjustable Mounting Bracket
12545-00	Weather Shield [SS]
07279-00	Weather Shield (EX d) [SS]
12556-00	Air Purge Adapter
12555-00	Air Purge Adapter (Ex d)
1800-101	Talentum Test Torch

MOUNTING

The Air Purge nozzle must be angled at 30° from horizontal in order to maximize the air flow over the front window.

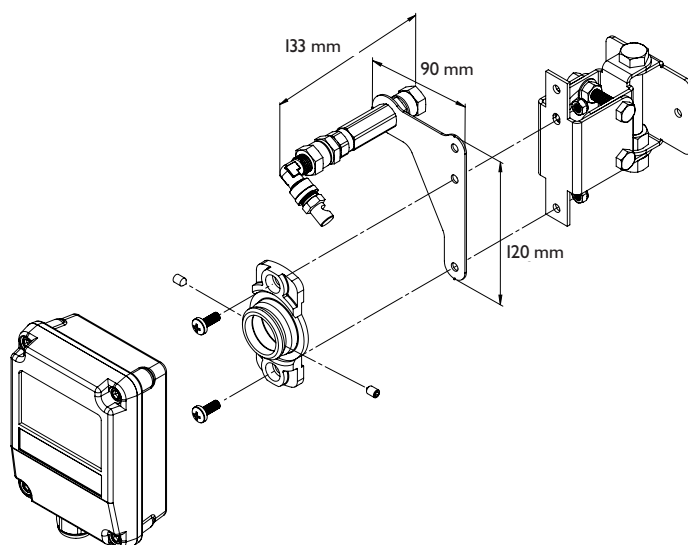

Specifications and wiring information are provided for information only and are believed to be accurate. FFE Ltd assumes no responsibility for their use. Data and design are subject to change without notice. Installation and wiring instructions are shipped with the products and should always be used for actual installation. For more information, contact your Sales Representative. Document Part No: 24-0122-03

